

5.7GiI-B, 5.7GXII-C

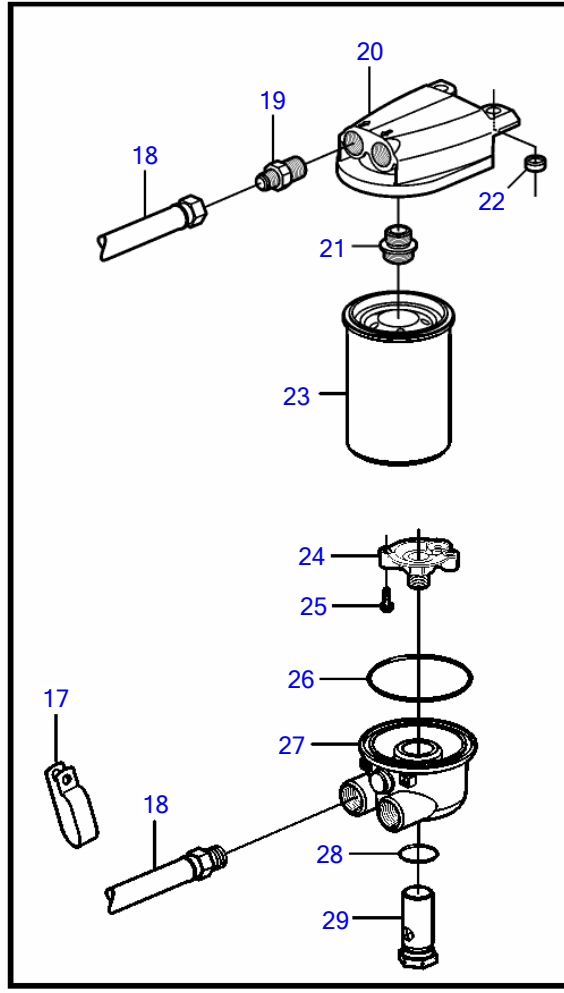
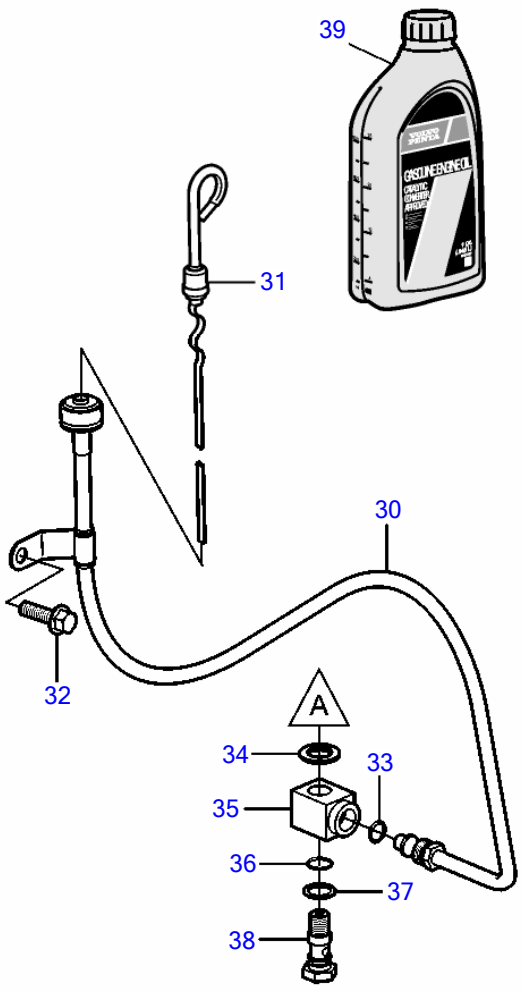
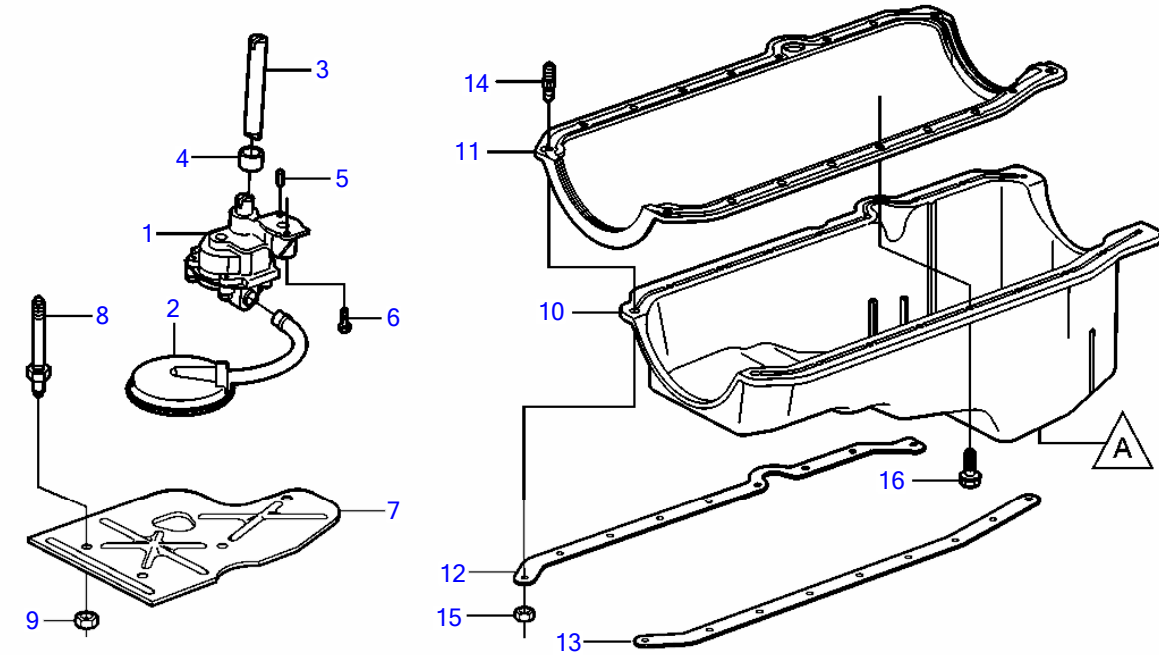

18618

5.7GiI-B, 5.7GXII-C

| REF | PART NO. | QTY | DESCRIPTION | SEE SEC. | NOTES |
|-----|-----------|-----|---------------------|-------------|--|
| 1 | 3856125 | 1 | Oil pump | | |
| 2 | 3856126 | 1 | Strainer | | |
| 3 | 3853198 | 1 | Shaft | | |
| 4 | 3853199 | 1 | Retainer | | |
| 5 | 3855972 | 2 | Pin | | |
| 6 | 3853234 | 1 | Bolt | | |
| 7 | 3852744 | 1 | Baffle | | |
| 8 | 3862354 | 6 | Stud | | |
| 9 | 3857664 | 5 | Nut | | |
| 10 | 3857778 | 1 | Sump | | |
| 11 | 3856138 | 1 | • Gasket kit | | |
| 12 | 3856121 | 1 | Reinforcement | | Starboard |
| 13 | 3856120 | 1 | Reinforcement | | Port |
| 14 | 3853202 | 4 | Stud | | |
| 15 | 3856930 | 4 | Nut | | |
| 16 | 3852595 | 14 | Bolt | | |
| 17 | 3860075 | 2 | Attaching clamp | | |
| 18 | 3860054 | 2 | Hose | | |
| 19 | 3860234 | 2 | Fitting | | |
| 20 | 3860450 | 1 | Adapter | | |
| 21 | 3852015 | 1 | • Connector | | |
| 22 | 1545204 | 1 | Spacer sleeve | | |
| 23 | 3850559 | 1 | Filter | | |
| | | | • Bulletin P-21-7-1 | P-21-7-1-EN | Oil Filters, GM gas engines |
| 24 | (3852219) | 1 | Valve | | Obsolete part |
| 25 | 3852133 | 2 | Screw | | |
| 26 | 3852470 | 1 | O-ring | | |
| 27 | (3860060) | 1 | Adapter | | Obsolete part |
| 28 | 3852089 | 1 | O-ring | | |
| 29 | 3853495 | 1 | Retainer | | |
| 30 | (3860402) | 1 | Tube | | Port, Obsolete part |
| | 3861360 | 1 | Tube | | Starboard |
| 31 | 3850474 | 2 | Gauge | | |
| 32 | (3853419) | 1 | Flange screw | | Port, Obsolete part |
| 33 | 3852033 | 2 | O-ring | | |
| 34 | 3851981 | 1 | Washer | | |
| 35 | 3858475 | 1 | Fitting | | |
| 36 | 3853674 | 1 | O-ring | | |
| 37 | 3852007 | 1 | Washer | | |
| 38 | 3850822 | 1 | Retainer | | |
| 39 | | X | Oil | 36050 | For current oil part numbers, follow link to "Maintenance Parts" page. |